

Front View

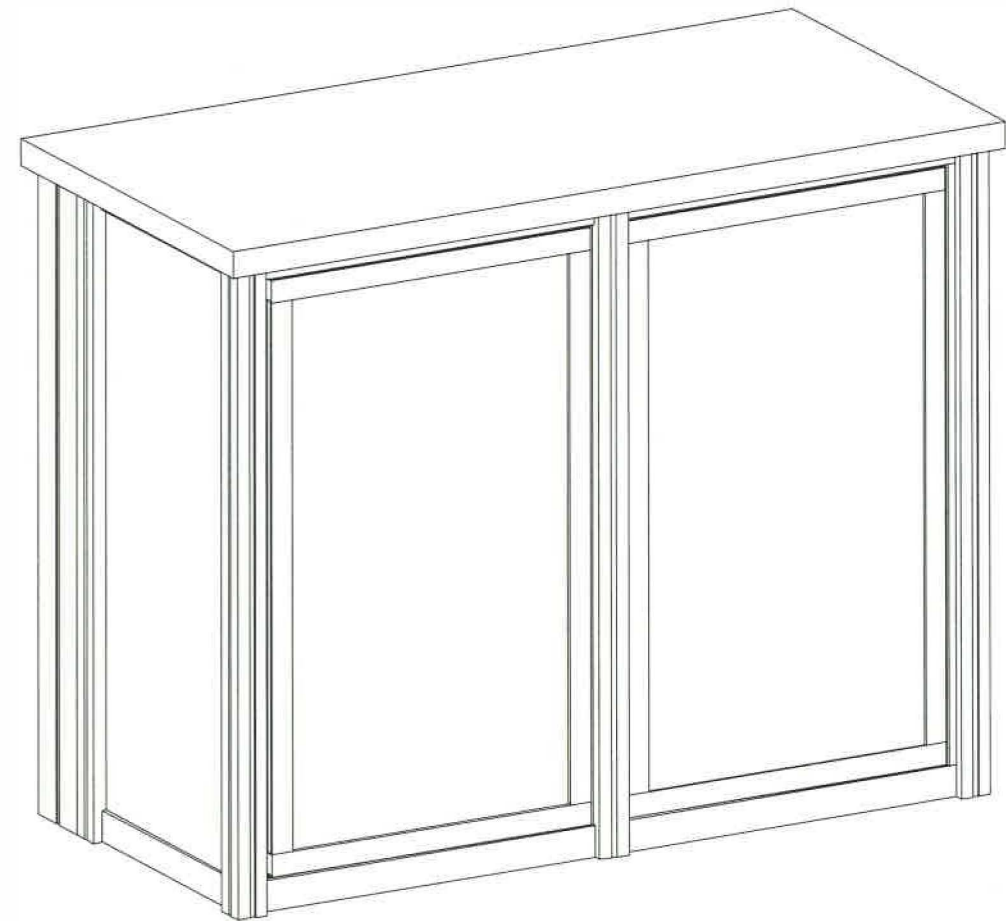

Back View

## ***SETUP INSTRUCTIONS***

## General Setup Instructions

- Read entire setup instruction manual prior to unpacking parts and pieces.
- The setup instructions are created specifically for this configuration.
- Setup instructions are laid out sequentially in steps, including exploded views with detailed explanation for assembly.

## Cleaning & Packing

- For Cleaning Metal, Plex, & Laminate Parts: Use a **MILD NON-ABRASIVE** cleanser and soft cloth/paper towel to clean all surfaces.
- Keep exhibit components away from heat and prolonged sun exposure. **Heat and UV exposure will warp and fade components.**
- Retain all provided Packing Materials. All provided packing materials are for ease of repacking & component protection.

## Disassembly

- For loss prevention, **tighten all setscrews and locks during disassembly**

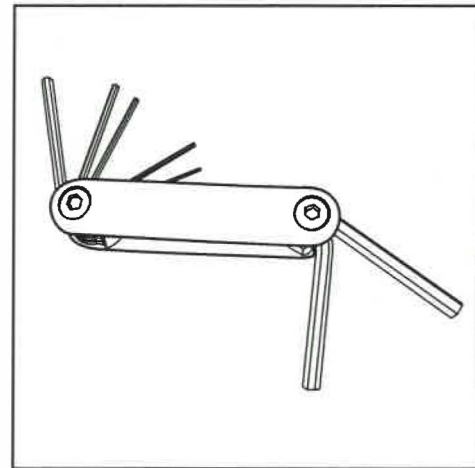

Hex Tool - Essential for Assembly

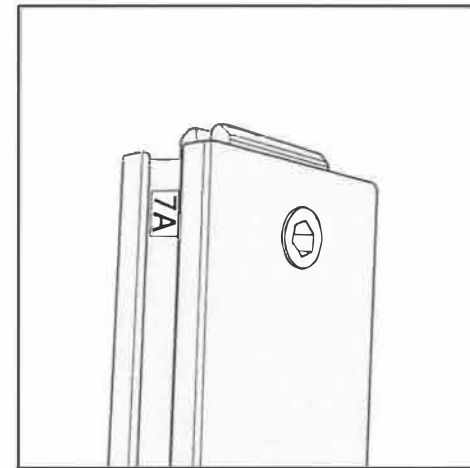

Part Identification - Numbering

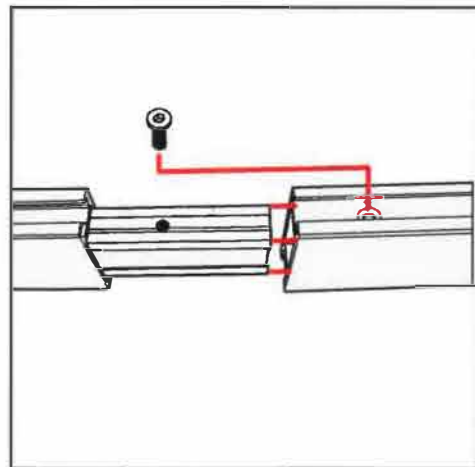

Spline Connection

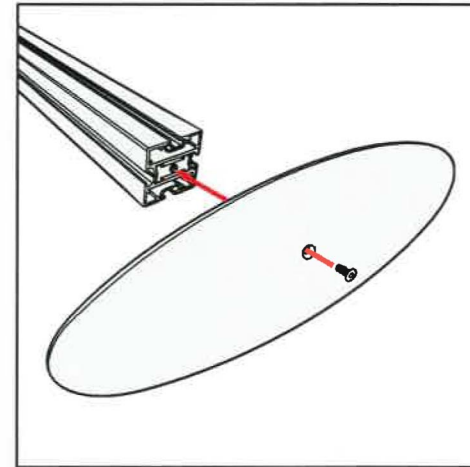

Base Plate & Extrusion Connection

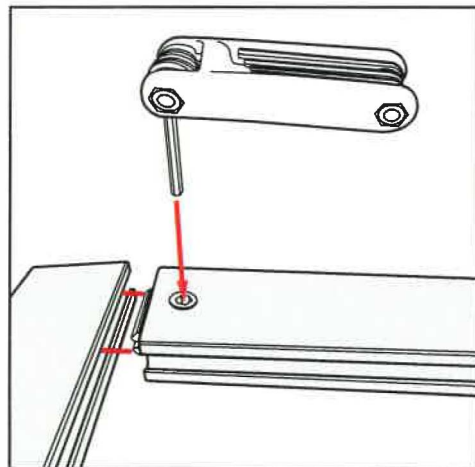

Extrusion & Lock Connection

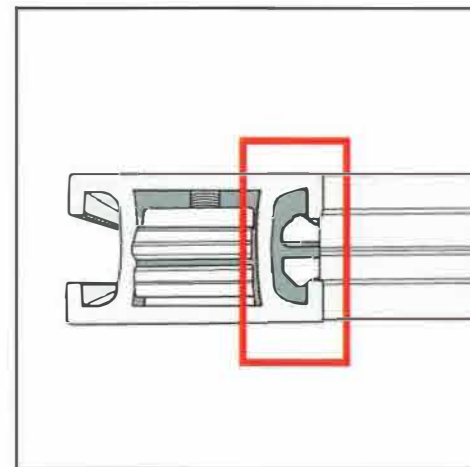

Engaged Lock



**WARNING**



DO NOT USE POWER TOOLS



LADDERS OR LIFTS  
MAY BE REQUIRED



ALL CONNECTIONS MUST  
BE TIGHTLY SECURED

## Corner Bracket Assembly

- 1) Slide TWO-PIECE **TS RV 2** L-bracket into Interior Center Slot of extrusion so that two set screws are inside groove. Tighten two set screws to secure.
- 2) Slide one **A1** L-Bracket into outer interior grooves of upper and lower horizontals. Tighten set screws to secure.
- 3) Slide vertical extrusion over exposed ends of brackets in lower horizontal. Tighten set screws to secure.
- 4) Slide exposed ends of installed brackets of upper horizontal into open ends of verticals. Tighten set screws to secure.

## Disassembly

- 1) Loosen set screws on brackets and slide extrusions off of brackets.

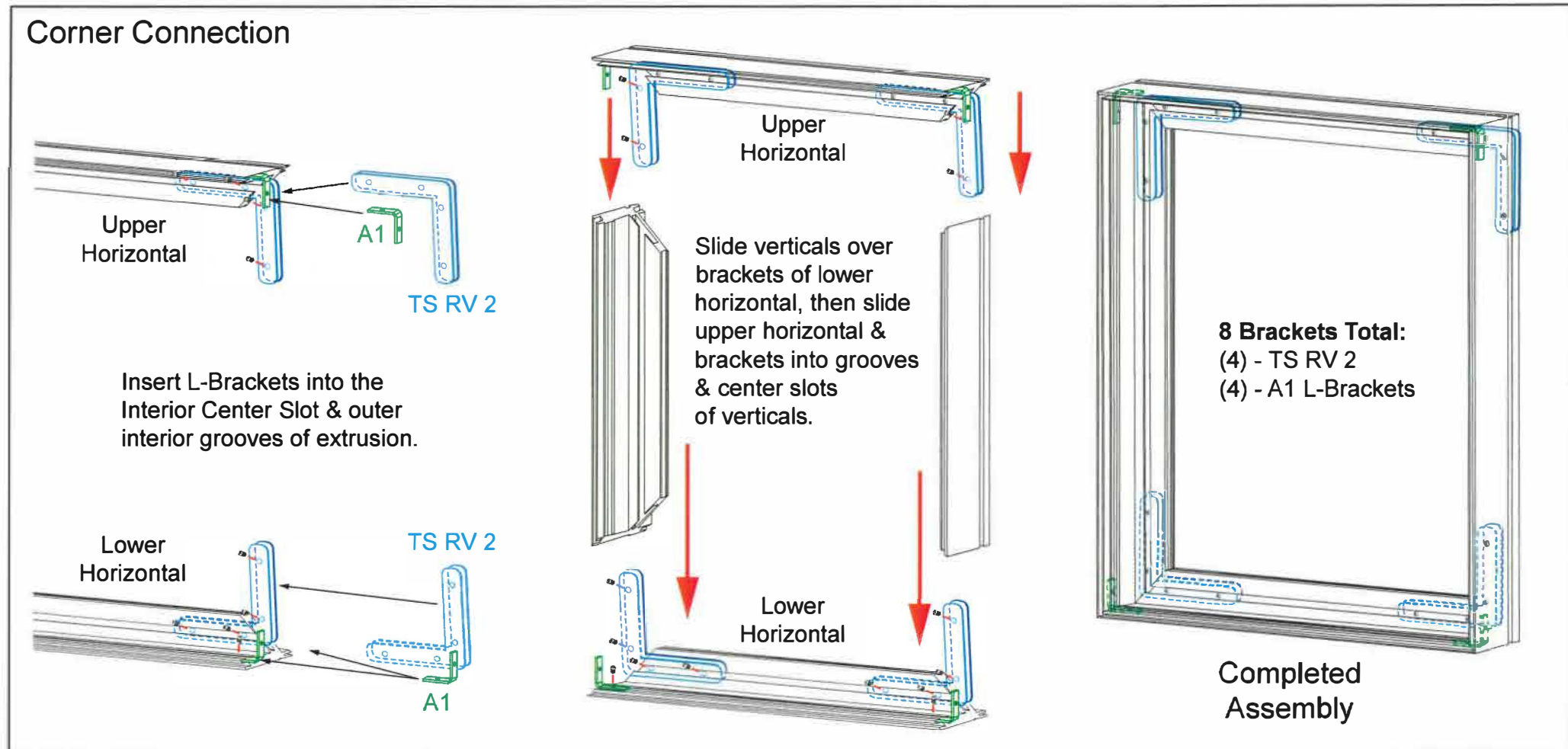

## Straight Bracket Assembly

- 1) Slide TWO-PIECE **TS RV 4** straight bracket into Interior Center Slot of extrusion, so that two of the set screws are inside groove. Tighten two set screws to secure.
- 2) Slide one **V4 Connector** into outer interior groove of extrusion, so that one set screw is inside groove. Tighten set screw.
- 3) Slide connecting extrusion over exposed ends of bracket & connector. Tighten all remaining set screws to secure extrusions.

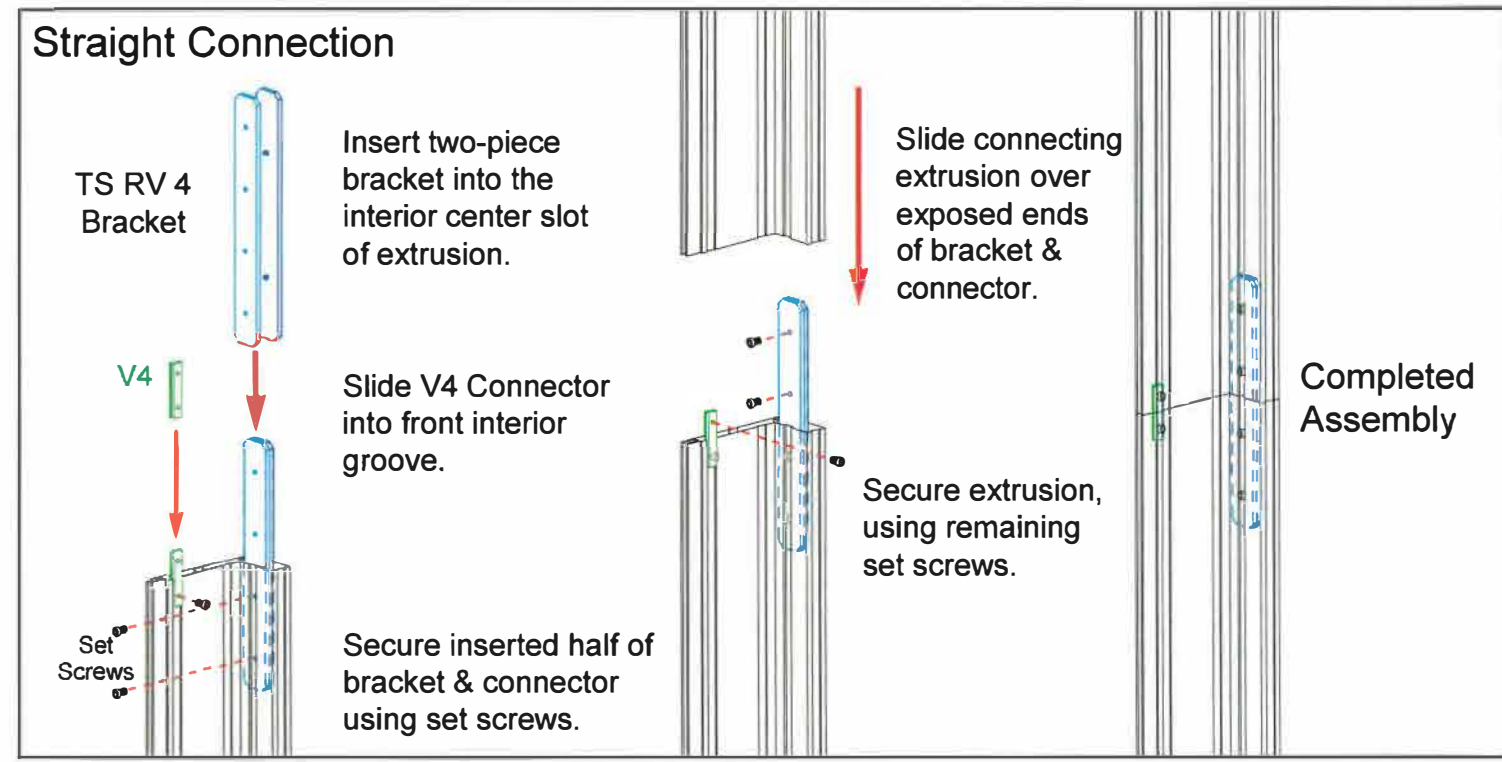
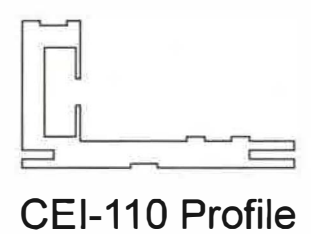



Item	Qty.	Description
1/1A	1/1	46.25" CEI-110 Horizontal Extrusion
2/2A	1/1	37.5" CEI-110 Vertical Extrusion
3/3A	1/1	37.5" S44 Vertical Extrusion
4	1	37.5" S44 Vertical Extrusion w/Door Hinges
5	1	37.5" S44 Vertical Extrusion w/Door Stops
6	1	37.5" S44 Vertical Extrusion w/Door Hinges
7/7A	2/2	14.153" Z45 Horizontal Extrusion
8/8A	2/2	20.408" Z45 Horizontal Extrusion

**Steps:**

- 1) Assemble frame extrusions [1,1A,2,2A]. See CEI-110 Frame Assembly sheet.
- 2) Connect lights and transformer. See **Light to Light Connection** and **Light to Transformer Connection** details.
- 3) Attach horizontal extrusions [7] & [8] between vertical extrusions [3,3A,4,5,6].
- 4) Slide infills between vertical extrusions [3,4] & [3A,6].
- 5) Connect doors between vertical extrusions [4,5] & [5,6]. See **Door Connection** detail.
- 6) Attach horizontal extrusions [7A] & [8A] between vertical extrusions [3,3A,4,5,6] and on top of infills and doors.
- 7) Connect shelf supports to Velcro on inside of infills and insert pins to vertical extrusions [3] [3A] & [5]. See **Shelf Pin** detail.

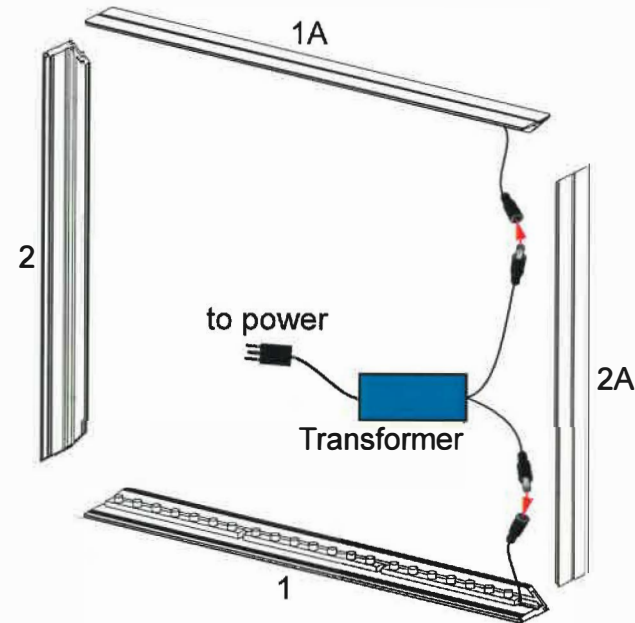

CEI-110 Frame Assembly

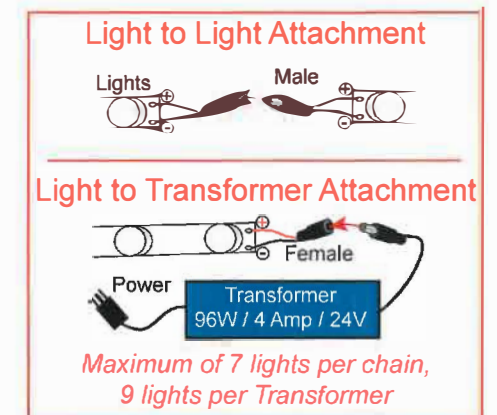
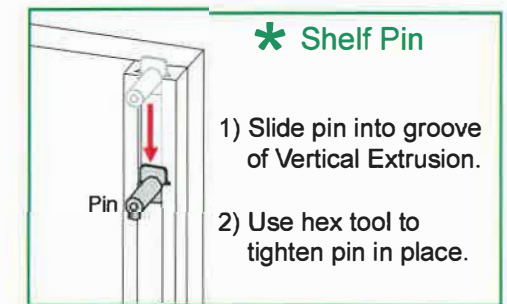
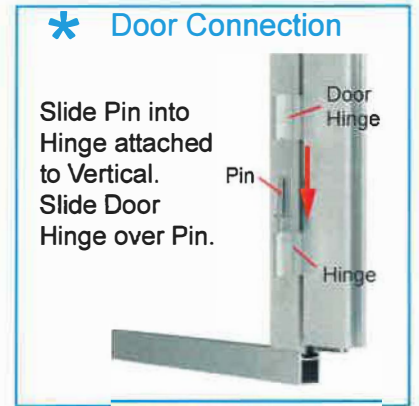
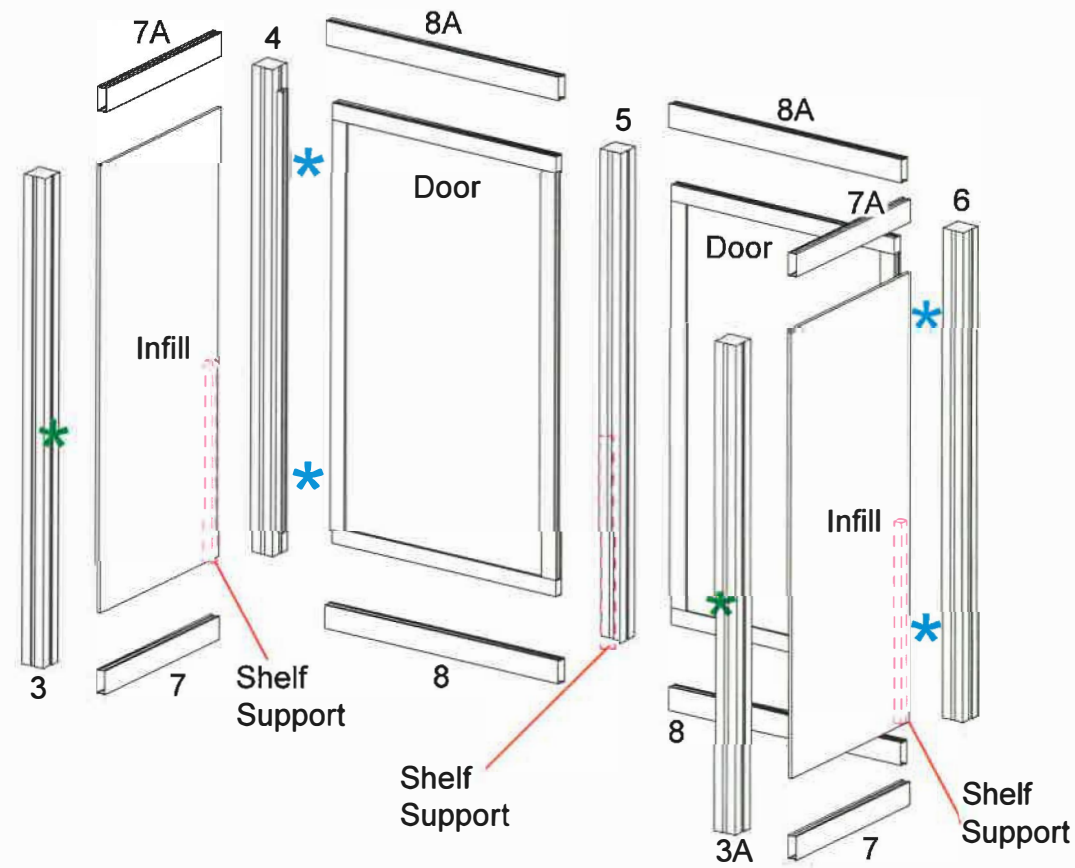

Steps:

- 1) Connect light blocker to Velcro on interior of assembled frame.
- 2) Attach assembled frame to verticals [3] & [3A].  
See [Frame Attachment](#) detail.
- 3) Install SEG graphic to front of assembled frame.  
See [SEG Graphic Installation](#) detail.
- 4) Place shelf inside assembled base on top of pins and supports.
- 5) Place counter top on assembled base, then secure with pins.  
See [Counter Top Attachment](#) detail.

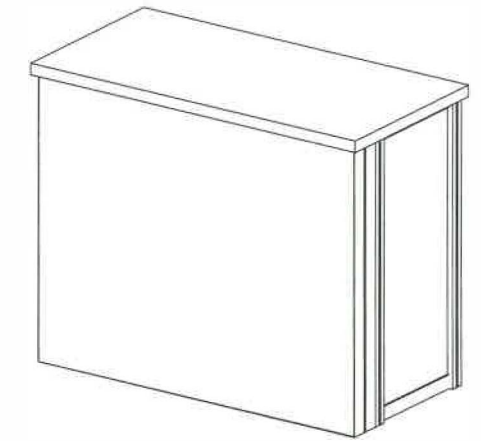
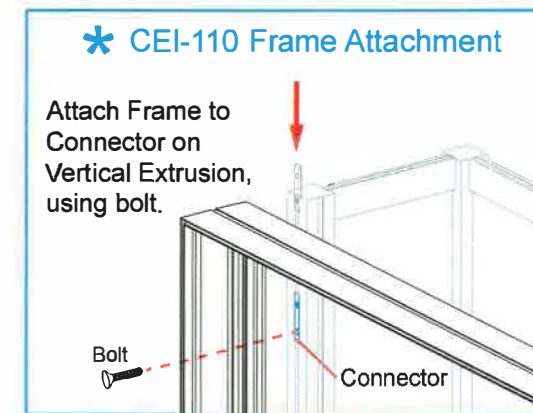
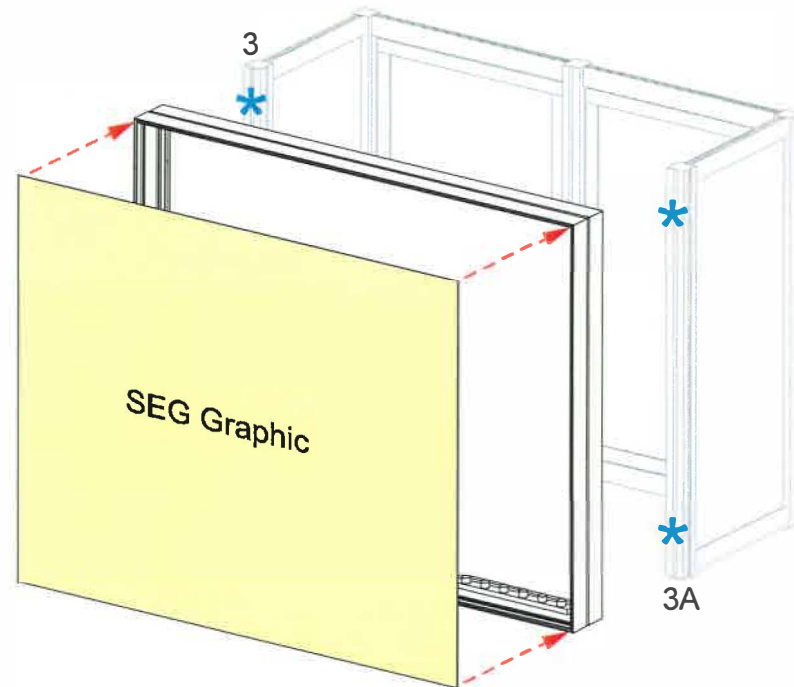
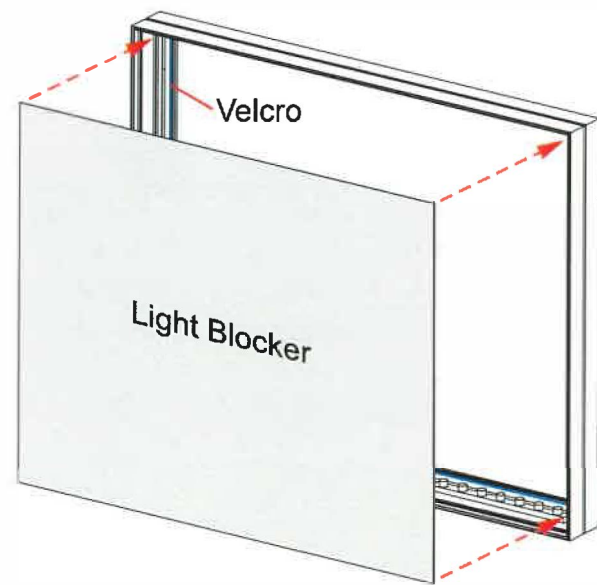

Completed Counter Assembly

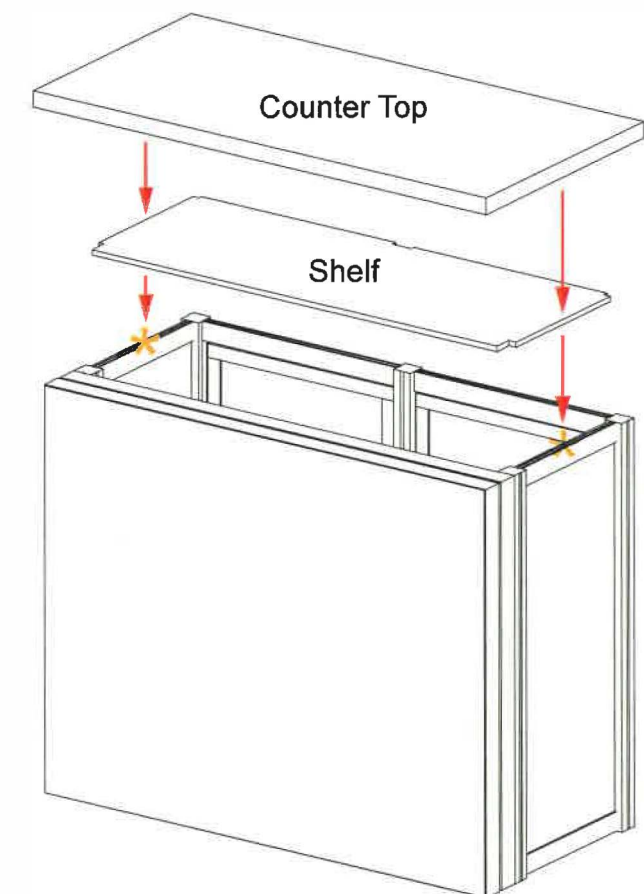

### SEG Graphic Installation

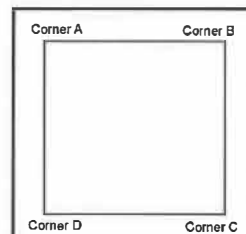

It is important to first insert graphic into each alternate corner then to the sides of the frame. If this is not done, graphic will not fit into the frame correctly.



**Step 1**  
Insert corner A. Turn edge of graphic so silicon welt is perpendicular to face of graphic. Insert narrow side of welt with fabric to outside into the channel. Repeat for other side of this corner.



**Step 2**  
Repeat Step 1 for opposite corner C, then insert corner D, to complete the installation of the corners.



**Step 3**  
Once all corners are inserted, press one silicon edge into channel from corners and work toward the center. Make sure welt is fully inserted into channel. Continue until all sides are done. Smooth out edges of graphic.

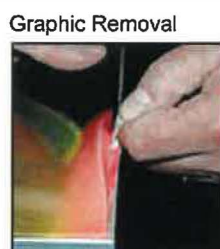

**Graphic Removal**  
To remove the graphic from the frame, locate the fabric pull tab. Gently pull up on the tab to remove the fabric.

### Counter Top Attachment

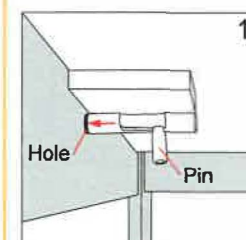

1  
Align hole with pin

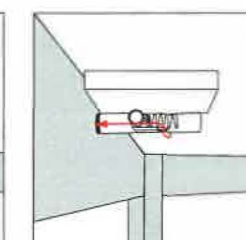

2  
Rotate pin. Spring will push pin into hole.